

## T15C Installation Guide

### 1 Safety Precautions

Both the installer and the owner and/or operator of the operator panel must read and understand this installation manual.

#### 1.1 General

- Read the safety precautions carefully.
- Check the delivery for transportation damage. If damage is found, notify the supplier as soon as possible.
- The supplier is not responsible for modified, altered or reconstructed equipment.
- Use only parts and accessories manufactured according to specifications of the supplier.
- Read the installation and operating instructions carefully before installing, using or repairing the operator panel.
- Never allow fluids, metal filings or wiring debris to enter any openings in the operator panel. This may cause fire or electrical shock.
- Only qualified personnel may operate the operator panel.
- Storing the operator panel where the temperature is lower/higher than recommended in this manual can cause the LCD display liquid to congeal/become isotopic.
- The LCD display liquid contains a powerful irritant. In case of skin contact, wash immediately with plenty of water. In case of eye contact, hold the eye open, flush with plenty of water and get medical attention.
- The figures in this manual serves an illustrative purpose. Because of the many variables associated with any particular installation, the supplier cannot assume responsibility for actual use based on the figures.
- The supplier neither guarantees that the operator panel is suitable for your particular application, nor assumes responsibility for your product design, installation or operation.
- It is recommended to turn on and shut down the operator panel at least once before installing any components/cards or before connecting the operator panel to external devices, like for example serial devices.

#### 1.2 During Installation

- The operator panel is designed for stationary installation on a plane surface, where the following conditions are fulfilled:
  - no high explosive risks
  - no strong magnetic fields
  - no direct sunlight
  - no large, sudden temperature changes
- Install the operator panel according to the accompanying installation instructions.
- Ground the operator panel according to the accompanying installation instructions.
- Only qualified personnel may install the operator panel.
- Separate the high voltage, signal and supply cables.
- Make sure that the voltage and polarity of the power source is correct before connecting the operator panel to the power outlet.
- Peripheral equipment must be appropriate for the application and location.

#### 1.3 During Use

- Keep the operator panel clean.
- Emergency stop and other safety functions may not be controlled from the operator panel.
- Do not use excessive force or sharp objects when operating the touchscreen.

#### 1.4 Service and Maintenance

- Only qualified personnel should carry out repairs.
- The agreed warranty applies.
- Before carrying out any cleaning or maintenance operations, disconnect the equipment from the electrical supply.
- Clean the display and surrounding front cover with a soft cloth and mild detergent.
- Replacing the battery incorrectly may result in explosion. Only use batteries recommended by the supplier. During the warranty period, the battery needs to be replaced by an authorized Beijer Electronics service center.
- The unit can be reset by using the reset switch located behind the fan.

#### 1.5 Dismantling and Scrapping

- The operator panel or parts thereof shall be recycled according to local regulations.
- The following components contain substances that might be hazardous to health and the environment: lithium battery, electrolytic capacitor and display.

#### 1.6 Appearance of Air in Touch Screen

The layer structure of the touch screen contains air and in rare cases appearance of bubbles can arise. This is purely cosmetic and does not affect any functionality of the operator panel. The appearance can occur under certain environmental conditions such as temperature, humidity, and atmospheric pressure.

## 2 Installation

### 2.1 Space Requirements

- Maximum installation plate thickness: 8 mm
- Space requirements in millimeters when installing the operator panel:

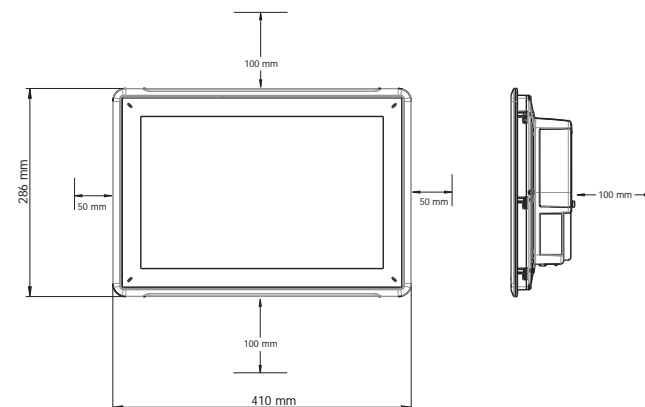

**Note:**  
The dimensions on the drawing are not proportional.

**Caution:**  
The openings on the enclosure are for air convection. Do not cover these openings.

### 2.2 Installation Process

The following is needed:

- A Torx TX7 screwdriver

1. Unpack and check the delivery. If damage is found, notify the supplier.

**Note:**  
Place the operator panel on a stable surface during installation. Dropping the operator panel or letting it fall may cause damage.

2. To cut a correct opening for the operator panel, use the cut out dimensions in the outline drawing. A separate cut out drawing is available for download from the Beijer Electronics web site. For more information, see sections [Operator Panel Drawings](#) and [Technical Data](#).
3. Secure the operator panel in position by screwing the M4 Torx screw, allowing the built-in bracket to tighten against the panel:

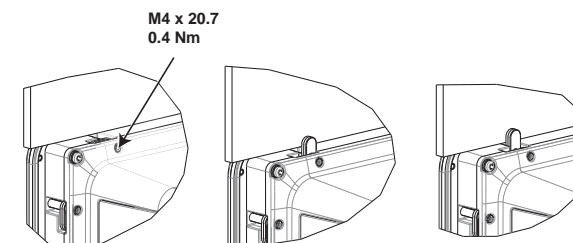

4. Connect the cables in the specified order, according to the drawing and steps below.

#### Caution:

- The operator panel must be brought to ambient temperature before it is started up. If condensation forms, ensure that the operator panel is dry before connecting it to the power outlet.
- Ensure that the operator panel and the controller system have the same electrical grounding (reference voltage level), otherwise errors in communication may occur.
- Ensure that the voltage and polarity of the power source is correct.
- Separate high voltage cables from signal and supply cables.
- Shielded communication cables are recommended.

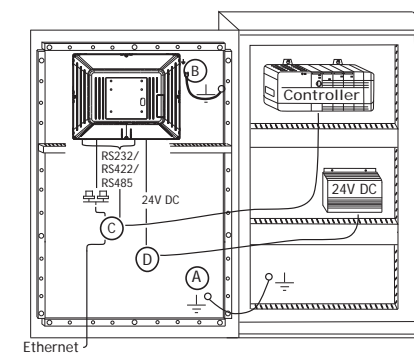

- Connect cable A.
- Connect cable B, using an M5 screw and a grounding conductor (as short as possible), that is sized correctly according to local electrical codes.
- Connect cable C.
- Connect cable D. The recommended cross-section of the cable is 2.5 mm<sup>2</sup>.

5. Carefully remove the laminated film over the operator panel display, to avoid static electricity that could damage the panel.

#### 2.2.1 Connections to the Controller

For information about the cables to be used when connecting the operator panel to the controller, please refer to the help file for the driver in question.

#### 2.2.2 Other Connections and Peripherals

Cables, peripheral equipment and accessories must be suitable for the application and its environment. For further details or recommendations, please refer to the supplier.

## 3 Technical Data

Parameter	T15C
Front panel, W × H × D	410 × 286 × 83 mm
Cut out dimensions, W × H	394 × 270 mm
Mounting depth	76 mm (176 mm including clearance)
Standalone mounting	VESA 100 × 100 Note: Maximum screw length for VESA mounting is 5.5 mm. Usage of longer screws may lead to damage.
Front panel seal	IP 65
Rear panel seal	IP 20
Touch screen material	Polyester on glass, resistive. Overlay: Autotex F157 or F207 <sup>(1)</sup> .
Touch screen operations	1 million finger touch operations
Reverse side material	Powder-coated aluminum
Frame material	Powder-coated aluminum
Weight	5.4 kg
Serial port for COM1 RS232 and COM2 RS422/RS485	9-pin D-sub contact with RS232 RTS/CTS, chassis-mounted female with standard locking screws 4-40 UNC Note: RS422 Interface is not available yet.
Serial port for COM3 RS232 and COM4 RS422/RS485	9-pin D-sub contact with RS232 RTS/CTS, chassis-mounted female with standard locking screws 4-40 UNC Note: RS422 Interface is not available yet.
Ethernet	2 × 10/100/1000 Base-T (shielded RJ45)
USB	4 × USB Host 2.0, max output current 500 mA
Processor	Intel® Celeron® B810E (2 × 1.6 GHz), 2 MB L2 Cache, Intel® QM67 Chipset Optional: Intel® Core™ i3 2310E (2 × 2.1 GHz) (Hyperthreading), 3 MB L2 Cache, QM67 Chipset Optional: Intel® Core™ i7 2715QE (4 × 2.1 GHz) (Turbo 2.0, Hyperthreading), 6 MB L2 Cache, QM67 Chipset *for exact configuration please see price list
External storage media	via USB
Memory RAM	2 GB* / 4 GB* DDR-3 SO-DIMM 1333 MHz *depending on Processor Module
LED	1 × multi-color
Real time clock	Yes (on chip)
Battery	Lithium battery type BR 2032 (or CR 2032), exchangeable
Power consumption at rated voltage	114 W
Fuse	10 A
Power supply	DC input range: 18 to 32 V DC (140 W) ATX standard CE: The power supply must conform with the requirements according to IEC 60950 and IEC 61558-2-4. UL and cUL: The power supply must conform with the requirements for class II power supplies.
Display	TFT-LCD with LED backlight. 1280 × 800 pixels, 16.7 million colors
VGA	1 × VGA: resolution max. 2048 × 1536@75Hz
DVI	1 × DVI-D single Link: Resolution max. 1600 × 1200 or 1920 × 1200 (with reduced blanking)
Active area of display, W × H	331.2 × 207.0 mm
Operating temperature	0 °C to +50 °C
Storage temperature	-20 °C to +70 °C

Parameter	T15C
Relative humidity	<85% non-condensed
Approvals and certifications	Information is available on the web site <a href="http://www.beijerelectronics.com">www.beijerelectronics.com</a>

(1) See section [Chemical Resistance](#) for more information.

## 4 Chemical Resistance

### 4.1 Metal Casing

The frame and casing material is powder-coated aluminum. This powder paint withstands exposure to the following chemicals without visible change:

Acetic acid 10%	Phosphoric acid 4%
Citric acid 10%	Phosphoric acid 10%
Diesel	Sea water
Distilled water	Sodium chloride 2%
Edible oil	Sodium chloride 20%
Fuel oil	Sulphuric acid 20%
Hydrogen peroxide 3%	Tap water

The powder paint shows limited resistance to the following chemicals at room temperature:

Butanol	Nitric acid 3%
Hydrochloric acid 5%	Nitric acid 10%
Isopropyl alcohol	Phosphoric acid 43%
Na-hypochlorite 10%	Turpentine
Sodium hypochlorite	

#### Note:

If exposure to any of the above chemicals is demanded, it is recommended to first test the chemical in a hidden spot of the metal casing.

The powder paint shows little or no resistance to the following chemicals at room temperature:

Acetic acid, conc.	Methyl-ethyl ketone	Toluene
Acetone	Nitric acid 30%	Trichlorethylene
Ammonia 5%	Phenol	Xylene
Ammonia, conc.	Sodium hydroxide 5%	97 octane unleaded petrol
Ethyl acetate	Sodium hydroxide 30%	98 octane leaded petrol

## 4.2 Touch Screen and Overlay

### 4.2.1 Autotex F157/207

Autotex F157 or F207 covers the overlay surrounding the screen.

#### Solvent Resistance

Autotex F157/F207 withstands exposure of more than 24 hours duration under DIN 42 115 Part 2 to the following chemicals without visible change:

Ajax / Vim in solution	Downy / Lenor <sup>(1)</sup>	Phosphoric acid (<30%)
Alkal carbonate solution <sup>(1)</sup>	Ethanol	Potassium ferricyanide
Ammonia (<40%) <sup>(1)</sup>	Glycerine	Potassium hydroxide (<30%)
Acetic acid (<50%)	Glycol	Pure Turpentine
Ariel powder in solution <sup>(1)</sup>	Gumption <sup>(1)</sup>	SBP 60/95 <sup>(1)</sup>
Bleach <sup>(1)</sup>	Hydrochloric acid (<36%)	Sulfuric acid (<10%)
Castor oil	Linseed oil	Tomato ketchup

Caustic soda (<40%) <sup>(1)</sup>	Methanol	Trichloroacetic acid (<50%)
Cutting oil	Nitric acid (<10%)	White Spirit
Cyclohexanol	Paraffin oil	Windex <sup>(1)</sup>
Diacetone alcohol	Persil powder in solution <sup>(1)</sup>	Wisk
Diesel	Petroleum spirit <sup>(1)</sup>	Acetonitrile

(1) Extremely faint glossing of the texture was noted.

Autotex withstands DIN 42 115 Part 2 exposure of up to 1 hour duration to glacial acetic acid without visible change.

Autotex is not resistant to high pressure steam at over 100 °C or the following chemicals:

Concentrated mineral acids	Benzyl alcohol
Concentrated caustic solution	Methylene chloride

### 4.2.2 Touch Screen Surface

The touch screen surface on the operator panel withstands exposure to the following solvents without visible change:

Solvents	Time
Acetone	10 minutes
Isopropanol	10 minutes
Toluene	5 hours

### 4.2.3 Touchscreen Protective Film

#### Autotex

It is recommended to use the Autoflex EBA 180L touch display protection film, that can be ordered from Beijer Electronics.

#### Outdoor Use

In common with all polyester based films, Autoflex EBA 180L is not suitable for use in conditions of long-term exposure to direct sunlight.

## 5 Operator Panel Drawings

### 5.1 Connectors

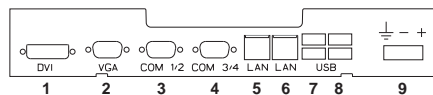

Pos.	Connector	Description
1	DVI	External monitor
2	VGA	External monitor
3	COM 3/4	Communication Ports
4	COM 1/2	Communication Ports
5	LAN Port B	1 × 10/100/1000 Base-T (shielded RJ45); Intel 82574
6	LAN Port A	1 × 10/100/1000 Base-T (shielded RJ45); Intel 82574
7	USB	2 × USB Host 2.0, max output current 500 mA
8	USB	2 × USB Host 2.0, max output current 500 mA
9	Power supply	DC input range: 18-32 V DC (140 W) ATX standard

## 5.2 Communication Ports

Pin	Serial port, 9-pin female		Serial port, 9-pin female	
	COM1	COM2	COM3	COM4
1	-	RS422 Tx+ RS485 Tx+/Rx+	-	RS422 Tx+ RS485 Tx+/Rx+
2	RS232 Rx D	-	RS232 Rx D	-
3	RS232 Tx D	-	RS232 Tx D	-
4	-	RS422 Rx+	-	RS422 Rx+
5	GND	GND	GND	GND
6	-	RS422 Tx- RS485 Tx-/Rx-	-	RS422 Tx- RS485 Tx-/Rx-
7	RS232 RTS	-	-	RS422 RTS+
8	RS232 CTS	-	-	RS422 RTS-
9	-	RS422 Rx-	-	RS422 Rx-

Note: RS422 Interface is not available yet.

#### Note:

In order to utilize two communication ports on the same physical port, the Y-split cable CAB109 must be used. Drawing for external cable CAB109 (drawing # Z7100-029E) is available on the web site: [www.beijerelectronics.com](http://www.beijerelectronics.com)

## 5.3 T15C Outline

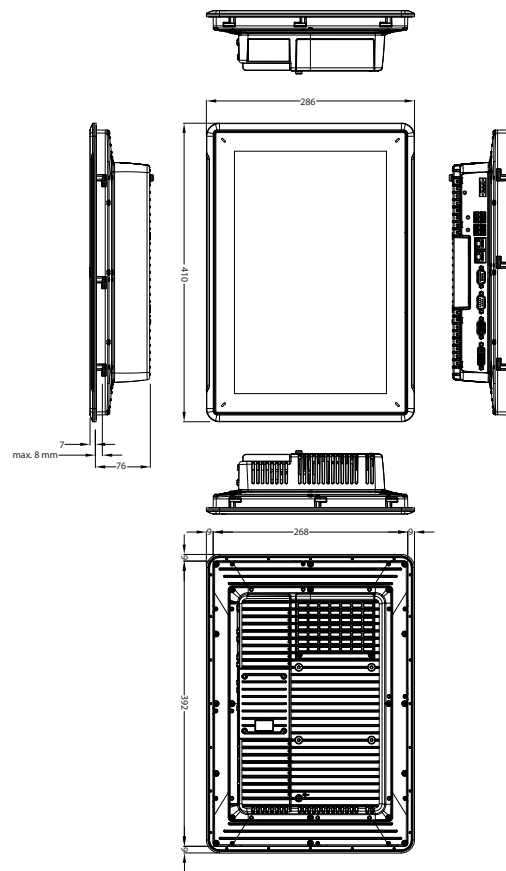

#### Note:

A Step CAD file is available on the web site [www.beijerelectronics.com](http://www.beijerelectronics.com)

Order no: MAEN483E

Copyright © 2014-04 Beijer Electronics. All rights reserved.

The information in this document is subject to change without notice and is provided as available at the time of printing. Beijer Electronics AB, including all its group companies, reserves the right to change any information without updating this publication. Beijer Electronics AB, including all its group companies, assumes no responsibility for any errors that may appear in this document. Read the entire installation manual prior to installing and using this equipment. Only qualified personnel may install, operate or repair this equipment. Beijer Electronics AB, including all its group companies, are not responsible for modified, altered or renovated equipment. Because the equipment has a wide range of applications, users must acquire the appropriate knowledge to use the equipment properly in their specific applications. Persons responsible for the application and the equipment must themselves ensure that each application is in compliance with all relevant requirements, standards and legislation in respect to configuration and safety. Only parts and accessories manufactured according to specifications set by Beijer Electronics AB, including all its group companies, may be used. BEIJER ELECTRONICS AB, INCLUDING ALL ITS GROUP COMPANIES, SHALL NOT BE LIABLE TO ANYONE FOR ANY DIRECT, INDIRECT, SPECIAL, INCIDENTAL OR CONSEQUENTIAL DAMAGES RESULTING FROM THE INSTALLATION, USE OR REPAIR OF THIS EQUIPMENT, WHETHER ARISING IN TORT, CONTRACT, OR OTHERWISE. BUYER'S SOLE REMEDY SHALL BE THE REPAIR, REPLACEMENT, OR REFUND OF PURCHASE PRICE, AND THE CHOICE OF THE APPLICABLE REMEDY SHALL BE AT THE SOLE DISCRETION OF BEIJER ELECTRONICS AB, INCLUDING ALL ITS GROUP COMPANIES.

# Beijer

ELECTRONICS

#### Head office

Beijer Electronics AB

Box 426

201 24 Malmö, Sweden

[www.beijerelectronics.com](http://www.beijerelectronics.com) / +46 40 358600